

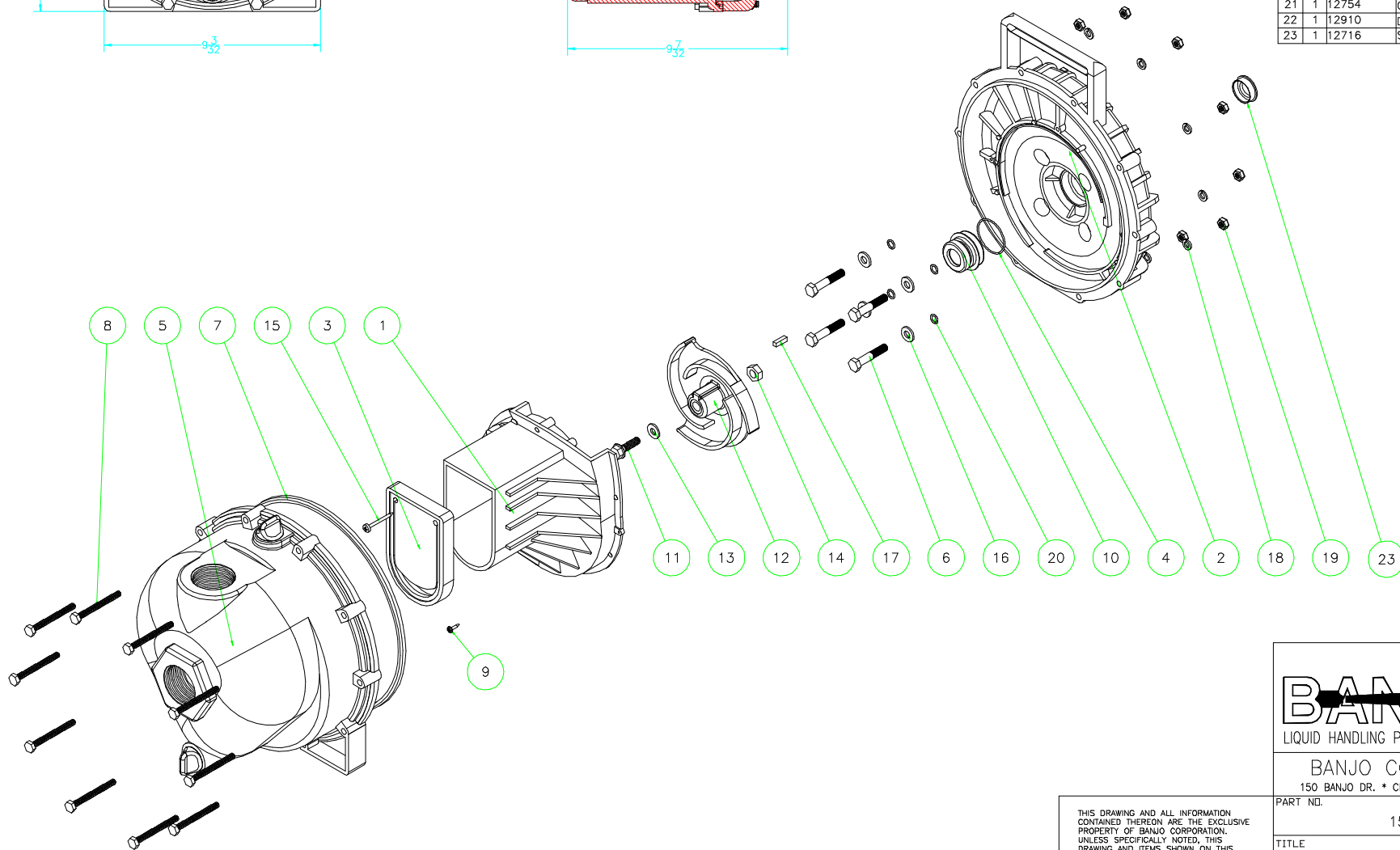

Parts List			
Item	Qty	PART NO.	DESCRIPTION
1	1	12702A	POLY PUMP VOLUTE
2	1	12703A	POLY PUMP REAR BRKT
3	1	12705	CHECK VALVE
4	1	12710	O'RING FOR SEAL ASSY
5	1	12711A	1 1/2" PUMP BODY
6	4	12715A	5/16-24 X 1 3/4 HHCS
7	1	12719A	PUMP BODY O'RING
8	10	12720	BODY SCREW
9	2	12725	#6 X 1/2" PPH SMS
10	1	12733	SEAL ASSEMBLY
11	1	12765A	5/16-24 X 1 1/8 HFS
12	1	12771A	3 VANE IMPELLER
13	1	12774VA	IMPELLER BOLT GASKET
14	1	12775A	7/16-14 HEX NUT
15	1	12900	#10 X 1 1/2" PPH SMS
16	4	12901	5/16" FLAT WASHER
17	1	12902A	3/16X3/16X5/8 KEY
18	10	V07018	1/4" SS LOCKWASHER
19	10	V07019	1/4" SS HEX NUT
20	4	12717	O'RING FOR SCREW HD
21	1	12754	O'RING SEGMENT (N/S)
22	1	12910	DECAL (N/S)
23	1	12716	SLINGER



THIS DRAWING AND ALL INFORMATION CONTAINED THEREON ARE THE EXCLUSIVE PROPERTY OF BANJO CORPORATION. UNLESS SPECIFICALLY NOTED, THIS DRAWING AND ITEMS SHOWN ON THIS DRAWING ARE SUBJECT TO CHANGE AT ANY TIME.



BANJO CORPORATION
150 BANJO DR. * CRAWFORDSVILLE, IN 47933

PART NO.	150PO
TITLE	1 1/2" POLY PUMP ONLY